

SPOT

THI DIGIT PN



ELECTREX[®]
welding since 1946

THI 30 DIGIT PN

kVA
30 Máx.
14 50%



(REF. PA07ELB008450)

Spot resistance welding machine with a maximum power of 30 KVA and mechanical foot pedal operation. 400V or 230V (optional) single-phase input with automatic detection of mains frequency. Position of arms and electrodes adjustable and compatible with a wide range of electrode shapes, allowing the welding of workpieces with different dimensions and shapes. Single or double current impulse (oxidized or galvanized plates). Indicated for production and repair in the automotive, naval, railway, aeronautics, bodywork and renewable energy industries.

Soudeuse par points avec une puissance maximale de 30 KVA à commande mécanique (PN). Alimentation monophasée de 400V ou 230V (en option) avec détection automatique de la fréquence. Position des bras et des électrodes réglable et compatible avec une large gamme d'électrodes, permettant le soudage de pièces de différentes dimensions et formes. Impulsion de courant simple ou double (tôles oxydées ou galvanisées). Indiquée pour la production et la réparation dans les industries automobiles, navales, ferroviaires, aéronautiques, de fabrication de carrosserie et d'énergies renouvelables.



Water cooled
Refroidissement eau



Electronic adjustment
Réglage électronique



Digit controller allows adjustment of welding current and time in simple impulse, the time between impulses and the current and the welding time of the second impulse

Contrôleur Digit Controller permet de régler le courant et le temps de soudage en impulsion simple, le temps entre les impulsions, le courant et le temps de soudage de la 2ème impulsion



Automatic detection of mains frequency
Détection automatique de la fréquence

Technical data

Caractéristiques techniques

Input voltage (std/optional) <i>Tension d'alimentation (std/option)</i>	400/230V (+/- 10%)
Frequency <i>Fréquence</i>	50/60 Hz
Fuses <i>Fusibles</i>	40A
Welding capacity (steel / stainless) <i>Capacité de soudage (acier/acier inox)</i>	4+4 - 15+15 2,5+2,5 - 8+8 mm/∅ mm
No-load voltage <i>Tension à vide</i>	1-3,4V
Short circuit current <i>Courant de court-circuit</i>	11kA
Max. electrode pressure (340/450mm) <i>Pression max. électrode (340/450mm)</i>	200 140 daN (7bar)
Electrode opening <i>Ouverture d'électrode</i>	30mm
Distance between arms (std/optional) <i>Distance entre bras (standard/option)</i>	200 320 mm
Arms length (std/optional) <i>Longueur des bras (std/option)</i>	340-480 200-1000 mm
Arms diameter <i>Diamètre des bras</i>	∅ 45mm
Electrode holder diameter <i>Diamètre porte-électrode</i>	∅ 25mm
Electrode diameter <i>Diamètre électrodes</i>	∅ 20mm
Noise level <i>Niveau de bruit</i>	<70 dB (A)
Air pressure <i>Pression de l'air</i>	4-8 bar
Water flow <i>Débit d'eau</i>	4 lt/min
Maximum cadence <i>Cadence max.</i>	max 172g/min

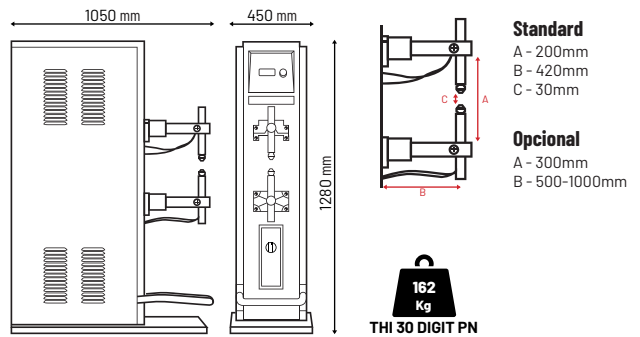
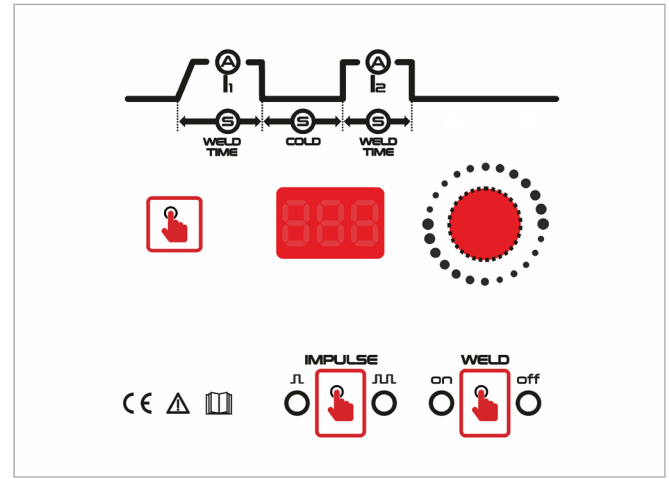

Accessories

Accessoires



Arm THI 450mm
Bras THI 450mm

REF. PFB340450NS



Electrode holder 25x190mm
Support électrode 25x190mm

REF. PFJ201900250255C



Electrode 20x47mm
Électrode 20x47mm

REF. PFH7L12010C04700



Water cooler Frigomix 6 THI
Refroidisseur Frigomix 6 THI

REF. PA11EL015

Option:
Option:

Position of arms and electrodes adjustable and compatible with a wide range of electrode shapes, allowing the welding of workpieces with different dimensions and shapes.
Position des bras et des électrodes réglable et compatible avec une large gamme d'électrodes, permettant le soudage de pièces de différentes dimensions et formes.

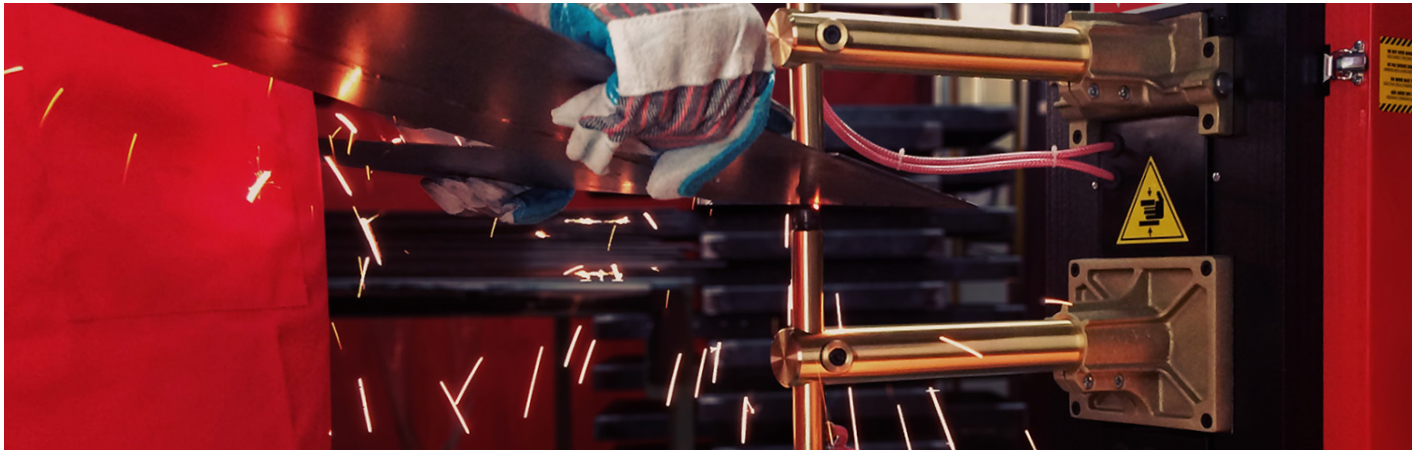

We reserve the right to change technical specifications without notice, non-contractual images.
Nous nous réservons le droit de modifier les spécifications techniques sans préavis, les images non contractuelles.