

## MMA/LIFTIG



# DC 503 CEL

500A 50%  
460A 60%  
355A 100%

DUTY CYCLE  
FACTEUR DE MARCHE  
(t=40°C 10 min)



(REF. PA14ELU139)

Inverter with three phase input for MMA and Liftig direct current (DC) welding. Excellent welding properties in basic, rutile and cellulosic electrodes, with adjustable Hot Start and Arc Force and pulsed MMA function for overhead, gapped workpieces, or different material thicknesses welds improving the end of the weld bead. Arc Off function that allows extinguish the arc at an adjustable distance without damaging the workpiece and pulsed Liftig option. Maximum mobility assured by carrying handles or modular integration in a car. Equipped with VRD system - Voltage Reduction Device - to reduce the no load voltage at the machine terminals.

Its power and robustness allow it to be used in the repair and maintenance sector, metal construction workshops, shipbuilding and other heavy work environments indoors or outdoors.

*Inverter triphasé pour le soudage MMA et Liftig en courant continu DC. Excellentes propriétés de soudage avec électrodes rutilés, basiques, et cellulosiques, avec Hot Start et Arc Force réglables et fonction MMA pulsé pour les soudures au plafond, les pièces avec écartement ou avec différentes épaisseurs de matériaux améliorant la fin du cordon. Fonction Arc Off qui permet d'éteindre l'arc à une distance réglable sans endommager la pièce et option Liftig pulsé. Mobilité maximale assurée par les poignées de transport ou le montage sur un chariot. Equipé d'un dispositif Voltage Reduction Device pour réduire la tension à vide sur les bornes de la machine. Sa puissance et sa robustesse lui permettent d'être utilisé dans les secteurs de la réparation et de maintenance, des industries métallomécaniques, de la construction navale et d'autres industries lourdes à l'intérieur ou à l'extérieur.*



When the welding voltage value set by the operator is reached, the arc extinguishes automatically to improve the end of the weld.

*Lorsque la valeur de tension de soudage réglée par l'opérateur est atteinte, la machine éteint automatiquement l'arc pour améliorer la fin du cordon de soudage.*



Real time MMA cycle (whenever the machine is in Hot Start, main current or Arc Force the corresponding indicator light lights).

*Cycle MMA en temps réel (à chaque fois que la machine est en mode Hot Start, courant principal ou Arc Force, le voyant correspondant s'allume).*



Low weight  
Faible poids



To prevent sticking of the electrode to the workpiece during welding

*Pour éviter le collage de l'électrode sur la pièce à souder pendant le soudage*



To improve arc ignition

*Pour améliorer l'amorçage de l'arc*



Integrated protection against overvoltage for secure connection to generators.

*Protection contre les surtensions intégrée pour une connexion sécurisée aux générateurs.*

# Technical data

## Caractéristiques techniques

Input voltage <i>Tension d'alimentation</i>	<b>3x400V (+/- 10%)</b>
Frequency <i>Fréquence</i>	<b>50/60 Hz</b>
Maximum primary current (MMA/TIG) <i>Courant primaire maxi. (MMA / TIG)</i>	<b>44/28A</b>
Maximum power (MMA/TIG) <i>Puissance maximale (MMA/TIG)</i>	<b>30,5/19,4 kVA</b>
Fuse <i>Fusible</i>	<b>32 A</b>
No-load voltage <i>Tension à vide</i>	<b>90 V</b>
Welding current <i>Courant de soudage</i>	<b>15-500 A</b>
Electrodes <i>Electrodes</i>	<b>Ø 10.0 mm</b>
Protection <i>Protection</i>	<b>IP 21S</b>
Insulation class <i>Classe d'isolation</i>	<b>H</b>

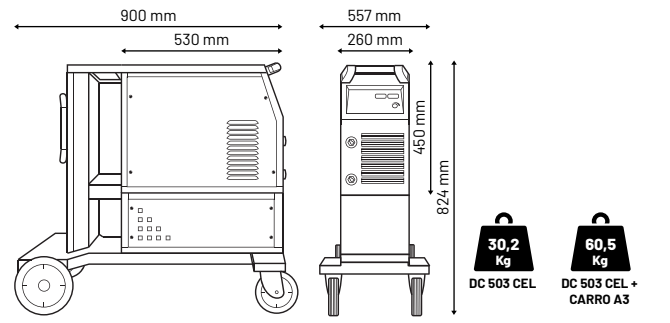
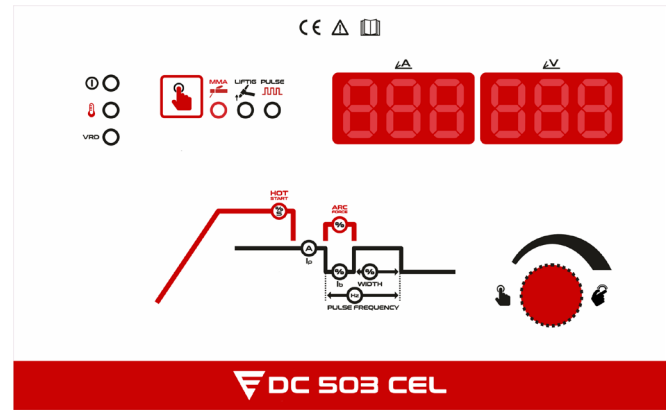

# Main Accessories

## Principaux Accessoires



Welding cables 500A  
*Jeu de câbles 500A*

REF. PF109812



Steel brush (4 row)  
*Brosse acier 4 rangs*

REF. C07PS1300254



Chipping hammer 525g  
*Marteau à piquer 525g*

REF. C08PC525

**New design more attractive, robust and versatile**  
*Nouveau design plus attrayant, robuste et polyvalent*



**Drawer option for DC Inverters, more convenient for storing your accessories.**  
*Option tiroir pour DC Inverters, plus pratique pour rangement des accessoires*

