



CATALOGUE
2024
WELDING
ACCESSORIES

OVER 70 YEARS OF EXPERIENCE IN THE FIELD OF WELDING

When João Rodrigues de Matos conceived the first welding equipment in 1946, it was far from imagining the importance and the repercussion that the Electrex brand currently has around the globe. Over 70 years, Electrex maintains a worldwide presence in the most diverse markets with great influence in the welding world. The accuracy and trust that characterize relationships with our customers are the key to seven decades of success.



WELDING SINCE
1946

Joseph P. ...

1917 - 2008

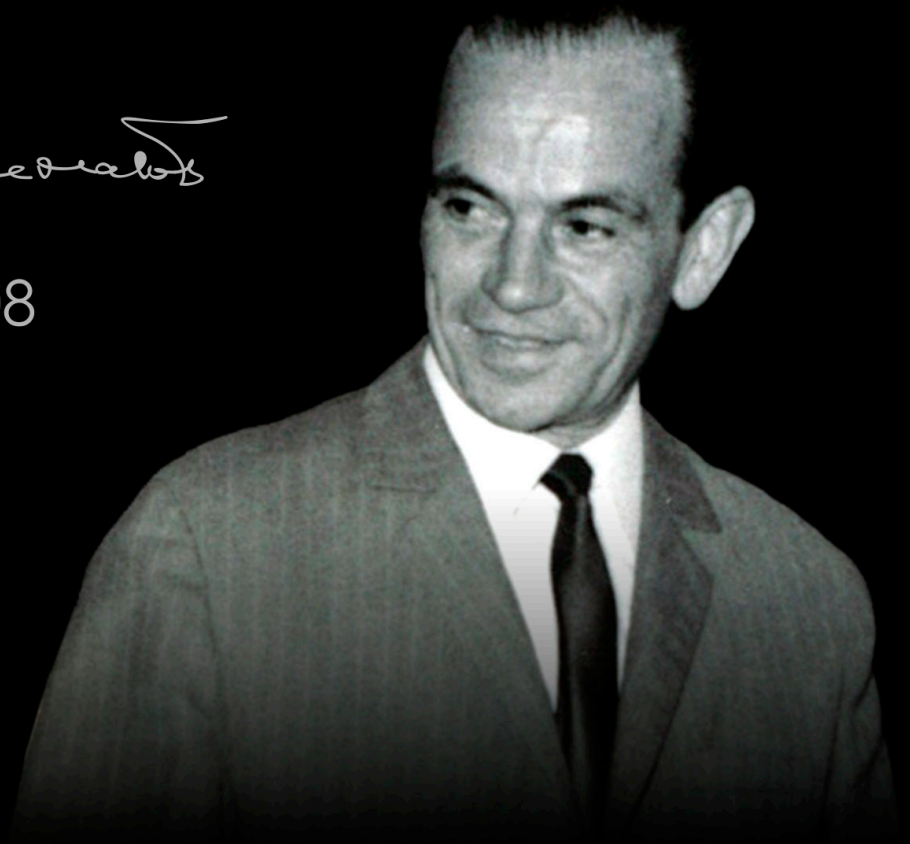

OVER 70 YEARS OF EXPERIENCE IN THE FIELD OF WELDING

A CUSTOMER-ORIENTED BRAND



Electrex places all its commitment and effort in satisfying the needs of its customers, offering solutions that are flexible and tailored to each one. Each order is executed with the utmost care and rigor to satisfy the needs of our customers.

HUMAN RESOURCES



The most valuable resource of a company is on the people who place their commitment into the organization every day. Electrex is aware of this value and therefore strives to meet the needs of its employees by providing them with the best possible working conditions in order to maintain a healthy and motivating work environment.

SUPPLIERS



Our suppliers are key components in the great gear that is Electrex and are carefully selected, from the moment of goods ordering to products arrival in the hands of our customers. They are the suppliers that help the organization to meet deadlines and objectives, so that the products are produced quickly and with quality, meeting the demand of our customers.

INOVATION



Electrex seeks to offer its customers more and better every day, and therefore it is requested the constant search for more innovative production processes in order to develop products of high demand and quality that satisfy the needs of our customers.

SUSTAINABILITY



Electrex is committed to keeping the planet free of pollution so that future generations can inhabit it in the same way. Electrex complies with all environmental and safety standards imposed by its competent authorities, both at European and global level.

FUTURE CHALLENGES



An investment in the production area and commitment to the latest production processes are some of the challenges that Electrex proposes, so that it can offer its customers the best welding equipment available in the market. Electrex takes its work as a welding equipment manufacturer very seriously and briefly intends to diversify its export markets and consolidate its presence in the existing ones.

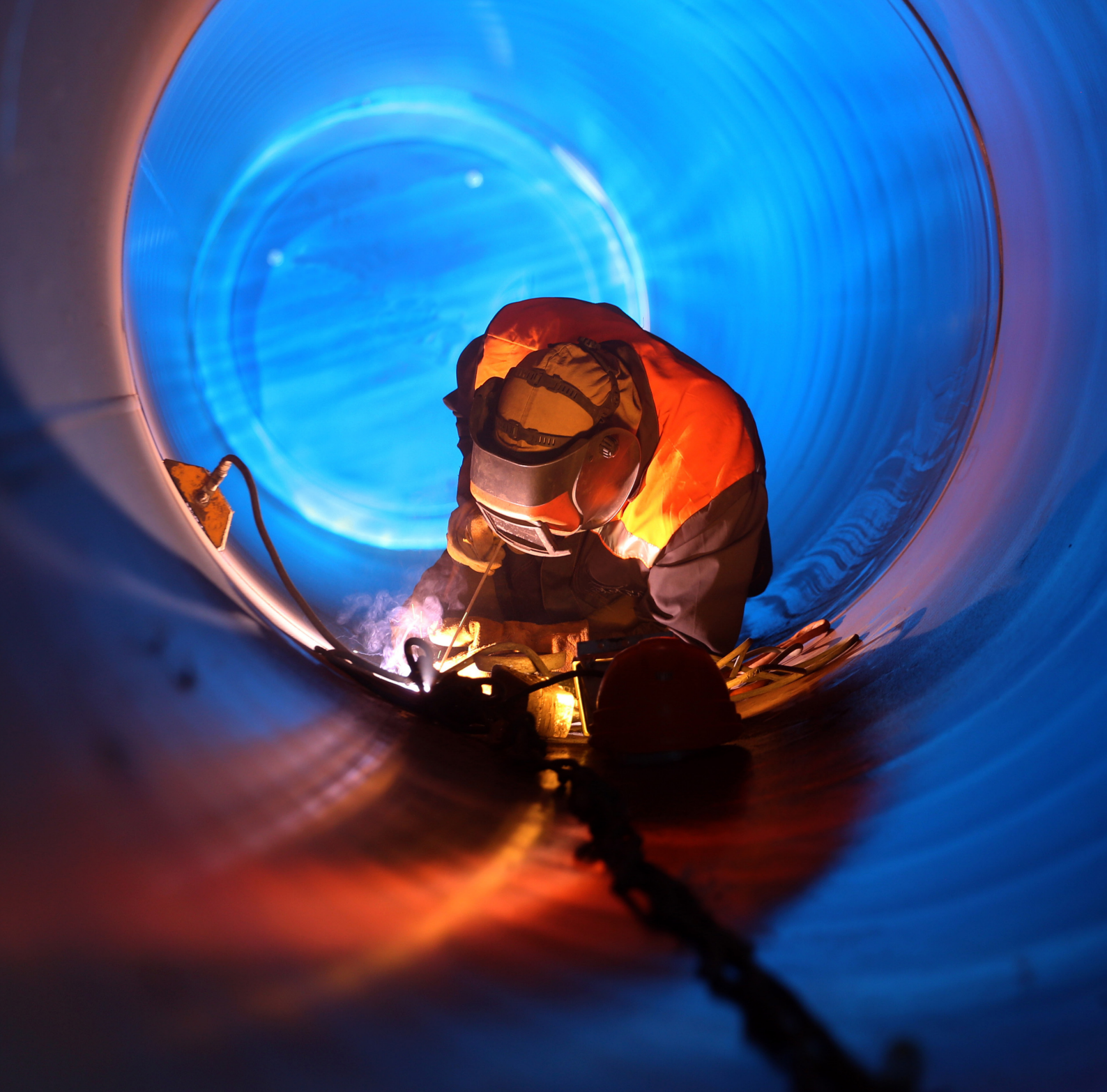

João R. Matos S.A. reserves the right to change the technical specifications without prior notice, non-contractual images.



Management System
ISO 9001:2015



www.tuv.com
ID 9108645664

INDEX

P. 7	Index
P. 8	Accessories and Consumables
P. 11	Protection Accessories
P. 12	MIG/MAG accessories
P. 20	TIG accessories
P. 30	SPOT accessories
P. 32	GAS accessories
P. 40	PLASMA accessories
P. 44	Electrex Services

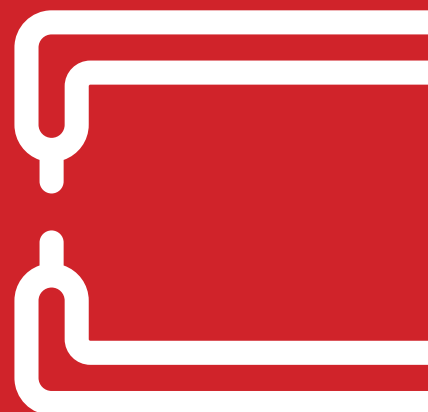
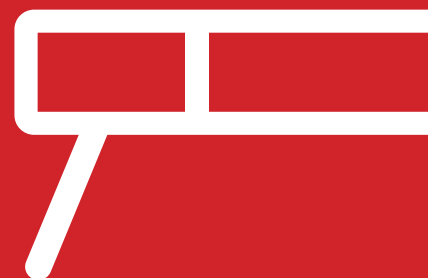





ACCESSORIES

Electrode holders		Ref.
	Electrode holder Eco 160A	CO7ASL16008
	Electrode holder Eco 200A	CO7ASL20012
	Electrode holder Eco 300A	CO7ASL30005
	Electrode holder Eco 400A	CO7ASL40005
	Electrode holder Eco 600A	CO104538
	Electrode holder Optimal 300A	CO7ASL30002
	Electrode holder Optimal 400A	CO7ASL40002
	Electrode holder Optimal 500A	CO7ASL50002
	Electrode holder Optimal 600A	CO7ASL60002
	Electrode holder Samson 300A	CC103043
	Electrode holder Samson 400A	CC103044
	Electrode holder Samson 600A	CC114283
	Electrode holder Screw type 300A	CC104539
	Electrode holder Screw type 400A	CC103601
	Electrode holder Screw type 600A	CC103602
Electrode holder 90° Progress 600A	CC104536	

Ground clamps / arc-air torches		Ref.
	Ground clamp OX 200A	CO7AMS20011
	Ground clamp OX 250A	CO7AMS25006
	Ground clamp OX 400A	CO7AMS40007
	Ground clamp OX 500A	CO7AMS50009
	Ground clamp OX 600A	CC114280
	Ground clamp OX 700A	CC114281
	Brass ground clamp OX 200A	CC114282
	Brass ground clamp OX 400A	CO7AMS60010
	Brass ground clamp OX 600A	CO7AMS70010
	Magnetic mass 600A	CC114284
	Arcair gouging torch ELECTREX 800A 2mt	CO7AA60017
	Arcair gouging torch ELECTREX 800A 5mt	PA101876
	Arcair gouging torch ELECTREX 1000A 2mt	CO7AA80017
	Arcair gouging torch ELECTREX 1000A 5mt	PA101877

Brushes / Chipping hammers		Ref.
	Brush-chipping hammer	CO7PM1265250
	Steel brush (2 row)	CO7PS1295252
	Steel brush (4 row)	CO7PS1300254
	Stainless steel brush (4 row)	CO7PS2295254
	Chipping hammer 225g	CO8PC225
	Chipping hammer 525g	CO8PC525
	Metal chipping hammer	CC114278
	Metal chipping hammer with spring handle	CC114279

Cable connections		Ref.
	Cable plug 25mm ²	CO7USM02525
	Cable plug 50mm ²	CO7USM05050
	Cable plug 70mm ²	CO7USM07070
	Cable plug 95mm ²	CO7USM09595
	Cable plug 120mm ²	CO104910
	Welding cable sockets 25mm ²	CO7USF02525
	Welding cable sockets 50mm ²	CO7USF05050
	Welding cable sockets 70mm ²	CO7USF07070
	Welding cable sockets 95mm ²	CO7USF09595
	Reduction adaptor m-f 25-50mm ²	CO7USMF2550
	Machine panel sockets 25mm ²	CO9NSF02525
	Machine panel sockets 50mm ²	CO9NSF05050
	Machine panel sockets 70mm ²	CO9NSF07070
Machine panel plug 70mm ²	CO105762	

Welding cable		Ref.
	Welding cable 10mm ²	MP09130100F00
	Welding cable 16mm ²	MP09130160F00
	Welding cable 25mm ²	MP09130250F00
	Welding cable 35mm ²	MP09130350F00
	Welding cable 50mm ²	MP09130500F00
	Welding cable 70mm ²	MP09130700F00
	Welding cable 95mm ²	MP09130950F00
	Welding cable 120mm ²	MP09131200F00



ACCESSORIES

Magnetic welding holder		Ref.
	Magnetic square holder 12kg	CC114285
	Magnetic square holder 20kg	CC114286
	Magnetic square holder 36kg	CC114287
	Magnetic square holder 43kg	CC114288

Electrode ovens		Ref.
	Electrode oven 5kg	CC102467
	Electrode oven 9kg	CC102468
	Electrode oven 22kg	CC102469
	Electrode oven 200kg	CC103612

Accessories for pipes		Ref.
	Pipe clamp 1-12.5" (25-60mm)	CC114848
	Pipe clamp 2-6" (50-150mm)	CC114849
	Pipe clamp 5-14" (125-360mm)	CC114850
	Pipe stand HJ (28-49" / 735-1190mm) 1135 Kg	CC114851
	Pipe stand HJ (32-52" / 810-1320mm) 2500 Kg	CC114855
	Steel wheel for pipe stand HJ	CC114852
	Rubber wheel for pipe stand HJ	CC114853

Gas regulators		Ref.
	Gas regulator ELECTREX Ar/CO2	CC104219
	Flowmeter ELECTREX Ar/CO2	CC104224
	Gas regulator ELECTREX Ar/CO2 mini	CC109068
	Gas regulator economizer ELECTREX	CC108184
	Gas flow tester	CC4000A131025
	O'ring	CC4000A102002

Other MMA accessories		Ref.
	Magnetic holder for electrode holder	CC109735
	Carrying case 42X34X25	CO6P246423425



Welding helmets		Ref.
 	Welding helmet ELECTREX S 413	CC111221
	Welding helmet ELECTREX X 413	CC111222
	Clear inner lens S-413	CC111428
	Clear outer lens S-413	CC111427
	Clear inner lens X-413	CC111433
	Clear outer lens X-413	CC111432
	Headband X-413	CC111435
	Headband S-413	CC111430
	Sweatband S-413	CC111431
	Sweatband X-413	CC111436
	Hand welding mask MM1010	PF109634
	Welding helmet MC1010	PF109633
	Flip lens welding helmet MC1010FU	PF108880
	Inner lens DIN10 50X105mm	CO9GI1050105
Inner lens DIN11 50X105mm	CO9GI1150105	
Inner lens DIN12 50X105mm	CO9GI1250105	
Clear outer lens 50X105mm	CO9GP0050105	

Gloves		Ref.
	Welding gloves MIG ELECTREX (L) (1)	CC111491
	Welding gloves MIG ELECTREX (M) (1)	CC111492
	Welding gloves MIG high temperature (L) (2)	CC111495
	Welding gloves TIG ELECTREX (L) (3)	CC111493
	Welding gloves TIG ELECTREX (M) (3)	CC111494

Clothing		Ref.
	Welding gaiters (1)	CC4006A110001
	Welding sleeves (2)	CC100275
	Welding apron (3)	CC4006A150001
	Welding coat (4)	CC104262
	Welding hood (5)	CC102881

Curtains and accessories		Ref.
	Orange curtain 1800X1300 (1)	CC4006P1418C1L
	Green curtain 1800X1300 (2)	CC103897
	Orange curtain 4 strips 1800X570mm (3)	CC4006P1418B2L
	Orange curtain 5 strips 1800X465mm (4)	CC4006P1418A1L
	Curatin suspension structure (5)	PA103349
	Curtain suspension ring (6)	CC4000P021040



MIG/MAG CONSUMABLES

MIG torches ELECTREX

MIG torch 15



Wire diameter:
Ø 0,6-1,0mm

CO2: 60% 180A
Mixed gas: 60% 150A

Torch 3m	CC107207
Torch 4m	CC107208

MIG torch 25



Wire diameter:
Ø 0,8-1,2mm

CO2: 60% 230A
Mixed gas: 60% 200A

Torch 3m	CC107209
Torch 4m	CC107210

MIG torch 36



Wire diameter:
Ø 0,8-1,2mm

CO2: 60% 320A
Mixed gas: 60% 290A

Torch 3m	CC107211
Torch 4m	CC107212
Torch 5m	CC114572

DIGIMIG torch 36



Wire diameter:
Ø 0,8-1,2mm

CO2: 60% 320A
Mixed gas: 60% 290A

Torch 3m	CC108734
Torch 4m	CC108735

MIG torch 40



Wire diameter:
Ø 1,0-1,6mm

CO2: 60% 400A
Mixed gas: 60% 380A

Torch 3m	CC113363
Torch 4m	CC113364

MIG torch 240W



Wire diameter:
Ø 0,8-1,2mm

CO2: 100% 300A
Mixed gas: 100% 270A

Torch 3m	CC110950
Torch 4m	CC110951

MIG torch 501W



Wire diameter:
Ø 1,0-1,6mm

CO2: 60% 500A
Mixed gas: 60% 450A

Torch 3m	CC107215
Torch 4m	CC107216
Torch 5m	CC114573

DIGIMIG torch 501W



Wire diameter:
Ø 1,0-1,6mm

CO2: 60% 500A
Mixed gas: 60% 450A

Torch 3m	CC108732
Torch 4m	CC108733

MIG torch 605W



Wire diameter:
Ø 1,0-1,6mm

CO2: 100% 600A
Mixed gas: 100% 550A
Pulse: 100% 450A

Torch 4m	CC108101
----------	----------

MIG torch Push-Pull

Wire diameter:
Ø 0,8-1,2mm
36 Spool
CO2: 60% 300A
Mixed gas: 60% 270A

Wire diameter:
Ø 0,8-1,2mm
36 Push-Pull
CO2: 60% 300A
Mixed gas: 60% 270A

Wire diameter:
Ø 1,0-1,6mm
401W Push-Pull
CO2: 60% 500A
Mixed gas: 60% 450A

36 Torch Spool 6m	CC113284
36 Torch Push-Pull 8m	CC109976
401W Torch Push-Pull 8m	CC108097

TBi Torch MOG 70



Wire diameter:
Ø 1,6-3,2mm

60% 430A

TBi Torch MOG 70	PA112294
------------------	----------



MIG/MAG Torches OX

MIG torch 15



3m	CC1015X181030
4m	CC1015X181040

MIG torch 24



3m	CC110205
4m	CC110206

MIG torch 25



3m	CC1025X181030
4m	CC1025X181040
5m	CC107174

MIG torch 36



3m	CC1036X181030
4m	CC1036X181040
5m	CC107175

MIG torch 501



3m	CC1501B181030
4m	CC1501B181040

Contact tips



	Ref.
Contact tip M6X6X0,6mm	CC1015A031061
Contact tip M6X6X0,8mm	CC1015A031062
Contact tip M6X6X1,0mm	CC1015A031063
Contact tip M6X8X0,8mm	CC1000A031062
Contact tip M6X8X1,0mm	CC1000A031063
Contact tip M6X8X1,2mm	CC1000A031064
Contact tip M6X8X1,6mm	CC1000A031065
Contact tip M8X10X0,8mm	CC1000A031082
Contact tip M8X10X1,0mm	CC1000A031083
Contact tip M8X10X1,2mm	CC1000A031084
Contact tip M8X10X1,6mm	CC1000A031085
Contact tip M8X10X2,0mm	CC1000A031086
Contact tip M8X10X2,4mm	CC1000A031087
Contact tip M6X8X0,8mm CuCrZr	CC1000A032062
Contact tip M6X8X1,0mm CuCrZr	CC1000A032063
Contact tip M6X8X1,2mm CuCrZr	CC1000A032064
Contact tip M8X10X0,8mm CuCrZr	CC1000A032082
Contact tip M8X10X1,0mm CuCrZr	CC1000A032083



MIG/MAG CONSUMABLES

Contact tip M8X10X1,2mm CuCrZr	CC1000A032084
Contact tip M8X10X1,6mm CuCrZr	CC1000A032085
Contact tip M8X10X2,4mm CuCrZr	CC1000A032087
Contact tip M10X12X1,2mm CuCrZr	CC108106
Contact tip M10X12X1,6mm CuCrZr	CC1000A032105
Contact tip M10X12X2,4mm CuCrZr	CC1000A032107
Contact tip M10X12X3,2mm CuCrZr	CC1000A032108



Nozzles

Ref.



Conical nozzle 15	CC1015A040001
Cylindrical nozzle 15	CC1015A040002
Bottle nozzle 15	CC1015A040003
Spot nozzle 15	CC1015A040004
Nozzle spring 15	CC1015A150000
Conical nozzle 24	CC1024A040001
Bottle nozzle 24	CC1024A0003
Conical nozzle 25	CC1025A040001
Cylindrical nozzle 25	CC1025A040002
Bottle nozzle 25	CC1025A040003
Spot nozzle 25	CC1025A040004
Nozzle spring 25	CC1025A150000
Conical nozzle 36	CC1036A040001
Cylindrical nozzle 36	CC1036A040002
Conical nozzle 40	CC1040A040001
Conical nozzle 40 ELECTREX	CC113367
Cylindrical nozzle 40 ELECTREX	CC113366
Conical nozzle 501	CC1501A040001
Bottle nozzle 501	CC113093
Cylindrical nozzle 501	CC113094
Conical nozzle 605	CC108105
Nozzle adaptor 605	CC108102
Ceramic cup MOG70 53N61S 12,7mm #8	CC112382



Diffusers / Contact tip holders		Ref.
	Right thread diffuser 15	CC1015A07200D
	Left thread diffuser 15	CC1015A07200E
	Ceramic diffuser 24	CC1024A07400A
	Contact tip holder 24 M6	CC1024A250M06
	Diffuser 25 M6	CC1025A07100D
	Diffuser 25 M8	CC100285
	Diffuser 36	CC1036A07300A
	Ceramic diffuser 36	CC1036A07400A
	Contact tip holder 36 M6	CC1036A250M06
	Contact tip holder 36 M8	CC1036A250M08
	Diffuser 40	CC1040A07300A
	Ceramic diffuser 40	CC1040A07400A
	Contact tip holder 40 M8	CC1040A250M08
	Diffuser 501	CC1501A07300A
	Ceramic diffuser 501	CC1501A07400A
	Contact tip holder 501 M6	CC1501A250M06
Contact tip holder 501 M8	CC1501A250M08	
Insulator swan neck 501	CC1401A130001	
Diffuser HP 605	CC108104	
Contact tip holder 605	CC108103	
Contact tip holder M10 MOG 70	CC105351	



MIG/MAG CONSUMABLES



Swan necks	Ref.
 Swan neck 15	CC1015A1401D0
Swan neck 24	CC1024A1401D0
Swan neck 25	CC1025A1401D0
Swan neck 36	CC1036A1401D0
Swan neck 36 automatic 45°	CC100587
Swan neck 36 straight automatic	CC1036A1402D0
Swan neck 40	CC1040A1401D0
Swan neck 40 ELECTREX	CC113365
Swan neck 240W ELECTREX	CC108757
Swan neck 501 ELECTREX	CC108153
Swan neck 501 automatic	CC101020
Swan neck 501 straight automatic	CC105444
Swan neck 605 ELECTREX	CC108757
Swan neck push-pull 36 45°	CC109984
Swan neck push-pull 36 straight	CC109985
Swan neck push-pull 401 45°	CC109986
Swan neck push-pull 401 straight	CC108098
Swan neck MOG 70	CC105350
Straight automatic handle	CC1000A200003

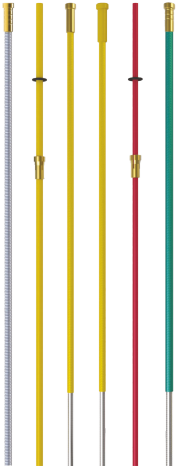









Liners		Ref.
	Steel liner 0,6-0,8mm 3m	CC1000A021083
	Steel liner 0,6-0,8mm 4m	CC1000A021084
	Steel liner 0,6-0,8mm 5m	CC1000A021085
	Steel liner 1,0-1,2mm 3m	CC1000A021123
	Steel liner 1,0-1,2mm 4m	CC1000A021124
	Steel liner 1,0-1,2mm 5m	CC1000A021125
	Steel liner 1,2-1,6mm 3m	CC1000A021163
	Steel liner 1,2-1,6mm 4m	CC1000A021164
	Steel liner 1,2-1,6mm 5m	CC1000A021165
	Steel liner 2,0-2,4mm 3m	CC1000A021243
	Steel liner 2,0-2,4mm 4m	CC1000A021244
	Steel liner 2,8-3,2mm 3m	CC1000A021323
	Steel liner 2,0-2,4mm 3m MOG 70	CC105352
	Steel liner 2,8-3,2mm 3m MOG 70	CC106511
	Teflon liner 0,8-1,0mm 3m	CC102379
	Teflon liner 0,8-1,0mm 4m	CC102380
	Teflon liner 0,8-1,0mm 5m	CC102381
	Teflon liner 1,0-1,2mm 3m	CC1000A022123
	Teflon liner 1,0-1,2mm 4m	CC1000A022124
	Teflon liner 1,0-1,2mm 5m	CC1000A022125
	Teflon liner 1,2-1,6mm 3m	CC1000A022163
	Teflon liner 1,2-1,6mm 4m	CC1000A022164
	Teflon liner 1,2-1,6mm 5m	CC1000A022165
	Spring for teflon liner 1,2mm	CC103870
	Spring for teflon liner 1,6mm	CC108439

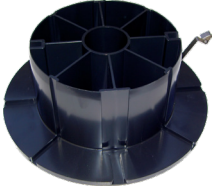

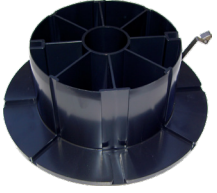
MIG/MAG CONSUMABLES

Sprays		Ref.
		PA113250
Cooling Electrex 5lt		CO7MELP0180
Anti spatter paste 250ml		CO7MELS0400
 	Anti spatter spray 400ml	CC109241
	Anti spatter spray ceramic 400ml	CC108087
	Leak detector spray ECO83	CC108088
	Anti spatter liquid G309 5 liters	CC102021
	Penetrating spray 12/34 400ml	CC105487
	Zinc spray 400ml	CC100918
	White revealing spray G164	CC100919
	Penetrating spray G151	CC103174
	Solvent and cleaner spray G153	CC10.00036
	Stainless steel spray 400ml	CC100652
Stainless steel weld cleaning gel 2Kg	CC109173	
Stainless steel weld soft cleaning gel 2Kg	CC10.10122	
Stainless steel cleaning gel brush		

Other MIG/MAG accessories		Ref.
        	Small wire spool adaptor	CC4000A160001
	Coil adaptor 300mm (15kg)	CC4000A160002
	Coil adaptor 415mm (25Kg)	CO105585
	Complete reel hub	CO104292
	Complete reel hub 25kg	CO105270
	Wire coil protection	CO108651
	Drum hood SG2/SG3	CC114496
	Wire straightener w/ 5 rolls for drum hood SG2/SG3	CC114497
	Wire conduit for drum hood SG2/SG3	CC114498
	MIG plier 12-15	CC100276
	MIG torch magnetic holder	CC102969
	Cylindrical ceramic weld pool backing 12mm	CC114427
	Round ceramic weld pool backing 6mm	CC114428
	Round ceramic weld pool backing 9mm	CC114429
Round ceramic weld pool backing 12mm	CC114430	
Half-round ceramic weld pool backing 6mm	CC114431	
Half-round ceramic weld pool backing 9mm	CC114432	

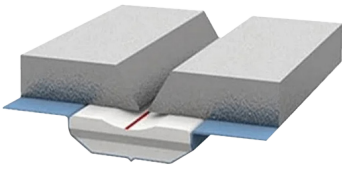

Half-round ceramic weld pool backing 13mm	CC114433
Flat ceramic weld pool backing 6mm	CC114434
Flat ceramic weld pool backing 9mm	CC114435
Flat ceramic weld pool backing 13mm	CC114436

ELECTREX TIG torches

TIG torch 9



DC: 35% 125A
AC: 35% 90A

Torch 4m	CC107200
Torch 4m Flex	PA113372
Torch 8m	CC108121
Torch 8m Flex	PA113373

TIG torch 17



DC: 35% 150A
AC: 35% 105A

Torch 4m	CC107201
Torch 4m Flex	PA113374
Torch 8m	CC107202
Torch 8m Flex	PA113375

TIG torch 26



DC: 35% 180A
AC: 35% 125A

Torch 4m	CC107203
Torch 4m Flex	PA112948
Torch 8m	CC107204
Torch 8m Flex	PA113376

TIG torch 28



DC: 35% 300A
AC: 35% 250A

Torch 4m	CC113385
Torch 8m	CC113386

TIG torch 20W



DC: 100% 225A
AC: 100% 160A

Torch 4m	CC108754
Torch 8m	CC108119

TIG torch 18W



DC: 100% 380A
AC: 100% 275A

Torch 4m	CC107205
Torch 4m Flex	PA112948
Torch 8m	CC107206
Torch 8m Flex	PA113377

TIG torch 45W



DC: 100% 450A
AC: 100% 360A

Torch 4m	CC113361
Torch 8m	CC113362

TIG torch 24W



DC: 100% 180A
AC: 100% 125A

Torch 4m	CC108755
----------	----------

V TIG torches ELECTREX

TIG torch 17V



DC: 35% 150A
AC: 35% 105A

Torch 4m	CC108751
Torch 8m	CC108752

TIG torch 26V



DC: 35% 180A
AC: 35% 125A

Torch 4m	CC108120
Torch 8m	CC108753

Others

TIG torch conector



CO107893

TIG torches Coldwire ELECTREX

TIG torch Coldwire

26 Coldwire
DC: 35% 180A
AC: 35% 125A
18W Coldwire
DC: 100% 380A
AC: 100% 275A



26 torch Coldwire 4m	PA107921
18W torch Coldwire 4m	PA107922

	Ref.
Mechanized wire feeding handle	PF108739
Manual wire feeding handle	PF101366
Coldwire contact tip 0,8-1,0mm	CC107064
Coldwire contact tip 1,2-1,6mm	CC107065
Coldwire wire feeding set for torches 17/26/18	CC2G05A19CW00

TIG torches Auto ELECTREX

OX TIG Torches

Auto TIG torch WP 27A



DC: 60% 500A
AC: 60% 300A

Torch 8m	CC104257
Torch 12m	CC111664

Auto TIG torch WP 27B



DC: 60% 500A
AC: 60% 300A

Torch 8m	CC104259
Torch 12m	CC111665

TIG torch 9



4m	CC2009A130S04
8m	CC2009A130S08

TIG torch 17



4m	CC2017H130S04
8m	CC100442

TIG torch 18



4m	CC2018A130S04
8m	CC2018A130S08

TIG torch 20



4m	CC2020H130S04
8m	CC2020H130S08

TIG torch 26



4m	CC2026H130S04
8m	CC2026H130S08

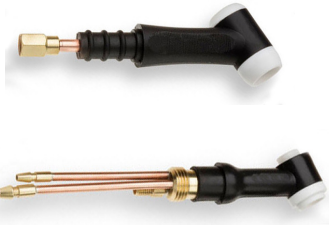

TIG ACCESSORIES

Tig torch head bodies	Ref.	
	Tig torch head body 9	CC103668
	Tig torch head body 9F	CC111343
	Tig torch head body 17	CC2017A020S00
	Tig torch head body 17V	CC2017A020V00
	Tig torch head body 17F	CC100650
	Tig torch head body 18	CC2018A020S00
	Tig torch head body 18F	CC108261
	Tig torch head body 18P	CC112626
	Tig torch head body 45W	CC113346
	Tig torch head body 20	CC2020A020S00
	Tig torch head body 20P	CC101295
	Tig torch head body 26	CC2026A020S00
	Tig torch head body 26F	CC100810
	Tig torch head body 26V	CC2026A020V00
	Tig torch head body 26VF	CC108312
	Tig torch head body auto 27A	CC111064

TIG torches switches	Ref.	
	ELECTREX standard switch	CC108093
	ELECTREX lever switch	CC109995
	ELECTREX potentiometer switch	CC108096
	ELECTREX 2 button switch	CC110926
	ELECTREX 3 button switch	CC108094
	ELECTREX 4 button switch	CC108095

TIG torches back caps	Ref.
Long back cap 57Y02	CC2G05A140L00
Long back cap 41V24	CC2G07A140L00
Long back cap 41V24L	CC112260
Long back cap 45W	CC113354
Medium back cap 41V35	CC2G07A140M00
Medium back cap 300M	CC107863
Short back cap 41V33	CC2G07A140C00
Short back cap 57Y04	CC2G05A140C00
Short back cap 45W	CC113355
Pyrex insulator 17/18/26 Jumbo	CC108986
Pyrex insulator 9/20 Jumbo	CC108991
Tig torch head body insulator 18CG	CC2G05A060000
Gas lens insulator 54N01	CC101398
Gas lens insulator 54N63 Jumbo	CC2G05A060001
Gas lens insulator 54N63-20 9/20 Jumbo	CC112612
Insulator 18-7	CC102950
Insulator 17GLF20 Stubby	CC108358
Insulator 18CG20 Stubby	CC108357
Insulator 598892 9/20	CC106432
Automatic TIG torch insulator 57N56	CC111066





TIG ACCESSORIES

Gas lens bodies	Ref.
 Gas lens body 1,0mm 45V24	CC2G05A101000
Gas lens body 1,0mm 45V42	CC2G07A101000
Gas lens body 1,6mm 45V25	CC2G05A101600
Gas lens body 1,6mm 45V43	CC2G07A101600
Gas lens body 1,6mm 45V43L Stubby	CC108352
Gas lens body Stubby 45V116S 1.6 mm	CC113096
Gas lens body 2,4mm 45V26	CC2G05A102400
Gas lens body 2,4mm 45V44	CC2G07A102400
Gas lens body 2,4mm 45V44L Stubby	CC108353
Gas lens body 2,4mm 45V64 Jumbo	CC2G05A102401
Gas lens body 2,4mm 45V64S Jumbo	CC112548
Gas lens body 2,4mm 49V24	CC111070
Gas lens body 3,2mm 45V27	CC2G05A103200
Gas lens body 3,2mm 45V45	CC2G07A103200
Gas lens body 3,2mm 49V25	CC111069
Gas lens body 3,2mm 995795 Jumbo	CC107994
Gas lens body 3,2mm 995795S Jumbo	CC112613
Gas lens body 4,0mm 45V28	CC2G05A104000
Gas lens body 4,0mm 49V26	CC113095
Gas lens body 45W	CC113356



Collets	Ref.
 Collet 1,0mm 17/18/26 10N22	CC2G05A071000
Collet 1,0mm 9/20/25 13N21	CC2G04A071000
Collet 1,0mm 24/24W 53N16	CC2G03A071000
Collet 1,6mm 17/18/26 10N23	CC2G05A071600
Collet 1,6mm 9/20/25 13N22	CC2G04A071600
Collet 1,6mm 9/20 13N22L Jumbo	CC113396
Collet 1,6mm 24/24W 53N14	CC2G03A071600
Collet 1,6mm 17/18/26 10N23S Stubby	CC108354
Collet 1,6mm 17/18/26 13N22 Stubby	CC108955
Collet 2,0mm 17/18/26 10N26	CC2G05A072000
Collet 2,0mm 70066 13N22M 9/20	CC2G01A072000



Collet 2,4mm 17/18/26 10N24	CC2G05A072400
Collet 2,4mm 17/18/26 Pyrex	CC113320
Collet 2,4mm 9/20/25 13N23	CC2G04A072400
Collet 2,4mm 9/20/25 13N23L Jumbo	CC112549
Collet 2,4mm 9/20 Pyrex	CC113318
Collet 2,4mm 24/24W 24C332	CC2G03A072400
Collet 2,4mm 17/18/26 10N24S Stubby	CC108355
Collet 2,4mm 17/18/26 13N23 Stubby	CC108956
Collet 2,4mm 57N47	CC111072
Collet 2,4mm 45W	CC113350
Collet 3,2mm 17/18/26 10N25	CC2G05A073200
Collet 3,2mm 17/18/26 Pyrex	CC113321
Collet 3,2mm 9/20/25 13N24	CC2G04A073200
Collet 3,2mm 9/20/25 13N24L Jumbo	CC112614
Collet 3,2mm 9/20 Pyrex	CC113319
Collet 3,2mm 57N48	CC111071
Collet 3.2 mm 45W	CC113351
Collet 4,0mm 17/18/26 54N20	CC2G05A074000
Collet 4,0mm 57N49	CC112625
Collet 4,0mm 45W	CC113352



TIG ACCESSORIES

Collet bodies	Ref.	
	Collet body 1,0mm 17/18/26 10N30	CC2G05A091000
	Collet body 1,0mm 9/20/25 13N26	CC2G04A091000
	Collet body 1,0mm 24/24W 53N18	CC2G03A091000
	Collet body 1,6mm 17/18/26 10N31	CC2G05A091600
	Collet body 1,6mm 9/20/25 13N27	CC2G04A091600
	Collet body 1,6mm 24/24W 53N19	CC2G03A091600
	Collet body 2,0mm 17/18/26 10N31M 13N27M)	CC2G05A092000
	Collet body 2,0mm 9/20 70067	CC2G01A092000
	Collet body 2,4mm 17/18/26 10N32	CC2G05A092400
	Collet body 2,4mm 9/20/25 13N28	CC2G04A092400
	Collet body 2,4mm 24/24W 24CB332	CC2G03A092400
	Collet body 3,2mm 17/18/26 10N28	CC2G05A093200
	Collet body 3,2mm 9/20/25 13N29	CC2G04A093200
	Collet body 3,5mm 17CB20 Stubby	CC108356
	Collet body 4,0mm 17/18/26 406488	CC2G05A094000
	Collet body Pyrex 17/18/26 Jumbo	CC108984
	Collet body Pyrex 9/20 Jumbo	CC108989
	Collet body 45W	CC113353



TIG electrodes

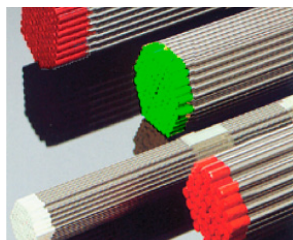

	Ref.
Electrode W 2% Thorium 0,8mm 150mm (red)	CC2000A042081
Electrode W 2% Thorium 1,0mm 150mm (red)	CC2000A042101
Electrode W 2% Thorium 1,2mm 150mm (red)	CC2000A042121
Electrode W 2% Thorium 1,6mm 150mm (red)	CC2000A042161
Electrode W 2% Thorium 2,0mm 150mm (red)	CC2000A042201
Electrode W 2% Thorium 2,4mm 150mm (red)	CC2000A042241
Electrode W 2% Thorium 3,2mm 150mm (red)	CC2000A042321
Electrode W 2% Thorium 4,0mm 150mm (red)	CC2000A042401
Electrode W 2% Cerium 1,6mm 150mm (gray)	CC101012
Electrode W 2% Cerium 2,0mm 150mm (gray)	CC101013
Electrode W 2% Cerium 2,4mm 150mm (gray)	CC101090
Electrode W 2% Cerium 3,2mm 150mm (gray)	CC103332
Electrode W pure 1,6mm 150mm (green)	CC2000A041161
Electrode W pure 2,4mm 150mm (green)	CC2000A041241
Electrode W pure 3,2mm 150mm (green)	CC2000A041321
Electrode W 2% La pure 1,6mm 150mm (blue)	CC101174
Electrode W 2% La pure 2,4mm 150mm (blue)	CC101175
Electrode W 2% La pure 3,2mm 150mm (blue)	CC103762
Electrode W 1% Zirconium 1,6mm 150mm (white)	CC103333
Electrode W 1% Zirconium 2,4mm 150mm (white)	CC103334
Electrode W 1% Zirconium 3,2mm 150mm (white)	CC103335
Electrode 1,5% Lanthanum 1,6mm 150mm (gold)	CC107872
Electrode 1,5% Lanthanum 2,4mm 150mm (gold)	CC107873
Electrode 1,5% Lanthanum 3,2mm 150mm (gold)	CC111074



Ceramic cups	Ref.
Ceramic cup 6,4mm 17/18/26 10N50 # 4	CC2G05A0111A0
Ceramic cup 6,4mm 9/20/25 13N08 # 4	CC2G04A0111A0
Ceramic cup 6,4mm 24/24W 53N24 # 4	CC2G03A0111A0
Ceramic cup 8,0mm 17/18/26 10N49 # 5	CC2G05A0111C0
Ceramic cup 8,0mm 9/20/25 13N09 # 5	CC2G04A0111C0
Ceramic cup 8,0mm 24/24W 53N25 # 5	CC2G03A0111C0
Ceramic cup 10N49L # 5	CC110209
Ceramic cup 9,8mm 17/18/26 10N48 # 6	CC2G05A0111E0
Ceramic cup 9,8mm 9/20/25 13N10 # 6	CC2G04A0111E0
Ceramic cup 9,8mm 24/24W 53N27 # 6	CC2G03A0111E0
Ceramic cup 9,8mm 45W	CC113347
Ceramic cup 10N48L # 6	CC110210
Ceramic cup 11,2mm 17/18/26 10N47 # 7	CC2G05A0111F0
Ceramic cup 11,2mm 9/20/25 13N11 # 7	CC2G04A0111F0
Ceramic cup 10N47L # 7	CC110211
Ceramic cup 12,7mm 17/18/26 10N46 # 8	CC2G05A0111G0
Ceramic cup 12,7mm 9/20/25 13N12 # 8	CC2G04A0111G0
Ceramic cup 12,7mm 45W	CC113348
Ceramic cup 15,7mm 17/18/26 10N45 # 10	CC2G05A0111H0
Ceramic cup 15,7mm 9/20/25 13N13 # 10	CC2G04A0111H0
Ceramic cup 15,9mm 45W	CC113349
Ceramic cup 19,0mm 9/20/25 13N09 # 12	CC2G05A0111J0
Pyrex cup 47mm 17/18/26 28.6mm Jumbo	CC108982
Pyrex cup 32.5mm 9/20 29mm Jumbo	CC108987
Gas lens ceramic cup 6,4mm 9/20/24/25 53N58 # 4	CC2G07A0112A0
Gas lens ceramic cup 6,4mm 17/18/26 54N18 # 4	CC112624
Gas lens ceramic cup 8,0mm 17/18/26 54N17 # 5	CC2G05A0112C0
Gas lens ceramic cup 8,0mm 9/20/24/25 53N59 # 5	CC2G07A0112C0
Gas lens ceramic cup 8,0mm 54N17L # 5	CC110207
Gas lens ceramic cup 9,8mm 17/18/26 54N16 # 6	CC2G05A0112E0
Gas lens ceramic cup 9,8mm 9/20/24/25 53N60 # 6	CC2G07A0112D0
Gas lens ceramic cup 9,8mm 54N16L # 6	CC101292
Gas lens ceramic cup 11,2mm 17/18/26 54N15 # 7	CC2G05A0112F0
Gas lens ceramic cup 11,2mm 9/20/24/25 53N61 # 7	CC2G07A0112F0





Gas lens ceramic cup 11,2mm 54N15L # 7	CC110208
Gas lens ceramic cup 12,7mm 17/18/26 54N14 # 8	CC2G05A0112G0
Gas lens ceramic cup 12,7mm 9/20/24/25 53N61S # 8	CC2G07A0112G0
Gas lens ceramic cup Jumbo 12,7mm 57N74 # 8	CC2G05A0114G0
Gas lens ceramic cup 15,7mm 17/18/26 53N88 # 10	CC2G05A0114H0
Gas lens ceramic cup 17,2mm 17/18/26 54N19 # 11	CC2G05A0112I0
Gas lens ceramic cup 19,0mm 17/18/26 53N87 # 12	CC103339

Pyrex gas diffusers



	Ref.
Pyrex gas diffuser 2.4mm Jumbo	CC108983
Pyrex gas diffuser 3.2mm Jumbo	CC108988

Other TIG accessories

	Ref.
Tungsten electrode sharpener GT-PULSE	CC113117
Tungsten electrode sharpener ST-40	CC113116
TIG torch magnetic holder	CC102968



ST-40

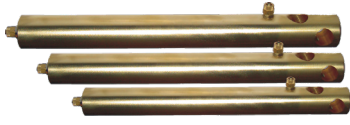

GT-Pulse

Arms		Ref.
	Arm THi 450mm	PFB340450NS
	Arm THi 450mm tubo	PFB340450TS
	Arm THi 600mm	PFB340600NS
	Arm THi 750mm	PFB340750NS
	Arm THi 900mm	PFB340900NS

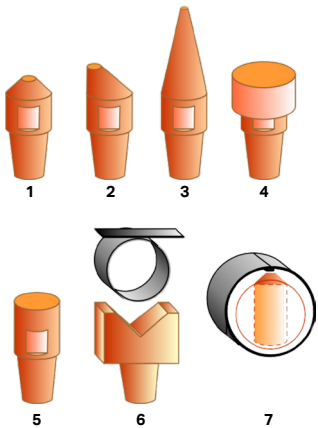
Spot welding electrodes		Ref.
	Standard electrode 20X47 CuCrZr	PFH7L12010C04700
	Standard electrode 20X47 CuCo2Be	PFH7J12010C04700
	Eccentric electrode 20X50	PFH7L22010C05007
	Long electrode 20X90	PFH7L12010C09000
	Long electrode 20X90 CuCo2Be	PF104172
	Long electrode 20X110	PF102318
	Rotule electrode 13/27	CC107393
	Rotule electrode 20X50	CC4000A19R205030
	Plain electrode 20X50	PF102836
	Electrode 20X50 diam. 6-11mm	PF104086
	External pipe electrode 30X50X74,5 water cooled	PFH7L60010C07400
	Internal pipe electrode 25X50 min. 60mm diam.	PFH7L32510C05000
	Internal pipe electrode 25X50 CuCo2Be	PF105071
	Lower electrode M3	PF131321
	Upper electrode M3 nut	PF131322
	Lower electrode M4 nut	PF131269
	Upper electrode M4 nut	PF131270
	Lower electrode M5 nut	PF131271
	Upper electrode M5 nut	PF131272
	Lower electrode M6 nut	PF131273
	Upper electrode M6 nut	PF131274
	Lower electrode M8 nut	PF131275
	Upper electrode M8 nut	PF131276
	Lower electrode M10 nut	PF131277
	Upper electrode M10 nut	PF131278
	Lower electrode M12 nut	PF131279
	Upper electrode M12 nut	PF131280



Capsule electrodes		Ref.
	Capsule electrode D-13	CO100436
	Capsule electrode L-13	CC100891
	Capsule electrode K-13	CC100892
	Capsule electrode M-13	CC100893
	Capsule electrode A-16	CO9SE11610C105
	Capsule electrode B-16	CO9SG11610C105
	Capsule electrode E-16	CO9SD11610C105
	Capsule electrode N-16	CO9SN11610C105

Electrode holders		Ref.
	Electrode holder 25X60 1/8 cpl	PFJ2Q0600250255C
	Electrode holder 25X190 1/8 cpl	PFJ2Q1900250255C
	Electrode holder 25X320 1/8 cpl	PFJ2Q3200250255C
	Electrode holder 25X380 1/8 cpl	PFJ2Q3800250255C
	Electrode holder capsule 20X50X13	PF102943
	Electrode holder capsule 20X50X16	PFJ2X0500200200S

Cooling pipes		Ref.
	Cooling pipe 5X8mm red	MP041208000150C1
	Cooling pipe 5X8mm blue	MP041208000150C2
	ELECTREX cooling pipe 6mm red	MP101607
	ELECTREX cooling pipe 6mm blue	MP104543

Other spot accessories		Ref.
	Electrode holder support d25X80mm	CC100084
	Electrode holder support d25X190mm	CC100085
	Electrode holder d19X125X55mm	CC100087
	Electrode holder d19X150X29,5mm	CC101305
	Electrode holder d16X200X29,5mm	CC104075
	Water cooling head 35-3/8G-1/8" cpl	PF103319



GAS ACCESSORIES

Gas regulators	Ref.	
	Pressure Regulator Oxygen 230/10bar	CC114633
	Pressure Regulator Oxygen 230/20bar	CC114641
	Pressure Regulator Oxygen 230/50bar	CC114642
	Pressure Regulator Acetylene 25/1,5bar	CC114634
	Pressure Regulator Acetylene 25/1,5bar Stirrup	CC114635
	Pressure Regulator Propane 4bar	CC114636
	Pressure Regulator Helium 230/10bar	CC114637
	Pressure Regulator-Balloon	CC114645
	Pressure Regulator Hydrogen 230/10bar	CC114638
	Pressure Regulator Nitrogen 230/4bar	CC114639
	Pressure Regulator Nitrogen 230/10bar	CC114640
	Pressure Regulator Nitrogen 230/20bar	CC114643
	Pressure Regulator Nitrogen 230/50bar	CC114644
	Pressure Regulator Mix Gas Argon/Co2 230/21l-min	CC114646
	Pressure Regulator-with flowmeter Argon/ Co2 230/30l-min	CC114647
	Pressure Regulator-with 2 flowmeter Argon/ Co2 230/30l-min	CC114648
	Point of use regulator (Oxygen 10bar)	CC114649
	Point of use regulator (Acetylene 1,5bar)	CC114650
	Point of use regulator (Propane 4bar)	CC114651
	Point of use regulator (Argon/Co2 21l-min)	CC114652
	Point of use regulator-with 2 flowmeter (Argon/Co2 30l-min)	CC114653
	Point of use regulator-with 1 flowmeter (Argon/Co2 30l-min)	CC114654



Other gas regulator accessories	Ref.
	Gas Economizer (Árgon/Co2) CC114655
	Gas Economizer-with adjustment knob (Árgon/Co2) CC114656
	Co2 Gas Heater 230V/75W CC114657
	Co2 Gas Heater 230V/150W CC114658
	Manometer 0- 40/25 bar (Ø 63 mm) Acetylene CC114659
	Manometer 0- 2,5/1,5 bar (Ø 63 mm) Acetylene CC114660
	Manometer 0- 315/230 bar (Ø 63 mm) Oxygen CC114661
	Manometer 0-16/10 bar (Ø 63 mm) Oxygen CC114662
	Manometer 0- 315/230 bar (Ø 63 mm) Árgon/Co2 CC114663
	Manometer 0- 32/21 l-min (Ø 63 mm) Árgon/Co2 CC114664
	Rubber Manometer Guard (Orange) single CC114665
	Rubber Manometer Guard (Blue) double CC114666
	Rubber Manometer Guard (red) double CC114667
	Rubber Manometer Guard (grey) double CC114668
	Nut G1/4 CC114669
	Nut G1/4L CC114670
	Nut G3/8 CC114671
	Nut G3/8L CC114672
	Nut G9/16 CC114673
	Nut G9/16L CC114674
	Nut M16x1,5 CC114675
	Nut M16x1,5L CC114676
	Hose Nipple G1/4 - Ø6-8mm CC114677
	Hose Nipple G1/4L - Ø6-8mm CC114678
	Hose Nipple G3/8 - Ø6-8mm CC114679
	Hose Nipple G3/8L - Ø6-8mm CC114680
	Hose Nipple G9/16 - Ø6-8mm CC114681
	Hose Nipple G9/16L - Ø6-8mm CC114682
	Hose Nipple M16x1,5 - Ø6-8mm CC114683
	Hose Nipple M16x1,5L - Ø6-8mm CC114684



GAS ACCESSORIES

Flashback arrestors

Ref.



Flashback Arrestors-for regulator-G3/8" (Oxygen)	CC114685
Flashback Arrestors-for regulator-G3/8" L (Gas)	CC114686
Flashback Arrestors-for cutting torch G1/4 (Oxygen)	CC114687
Flashback arrestor male quick connector-G1/4"	CC114688
Flashback arrestor female quick connector-Ø6-Ø8 nipple side	CC114689
Flashback Arrestors-for cutting torch G3/8L (Gas)	CC114690
Flashback arrestor male quick connector-G3/8" L	CC114691
Flashback arrestor female quick connector-Ø6-Ø8 nipple side	CC114692
Flashback Arrestors-for cutting torch G9/16x18 (Oxygen)	CC114693
Flashback arrestor male quick connector-UNF 9/16"x18	CC114694
Flashback arrestor female quick connector-Ø6-Ø8 nipple side (G9/16x18)	CC114695
Flashback Arrestors-for cutting torch G9/16x18L (Gas)	CC114696
Flashback arrestor male quick connector-UNF 9/16"x18 L	CC114697
Flashback arrestor female quick connector-Ø6-Ø8 nipple side (G9/16x18L)	CC114698
Male quick connector Oxygen Ø6-8mm	CC114699
Male quick connector Acetylene Ø6-8mm	CC114700
Flashback Arrestors-for cutting torch G1/4 - Ø6-8mm (Oxygen)	CC114701
Flashback Arrestors-for cutting torch G3/8L - Ø6-8mm (Gas)	CC114702
Flashback Arrestors-for cutting torch G9/16 - Ø6-8mm (Oxygen)	CC114703
Flashback Arrestors-for cutting torch G9/16L - Ø6-8mm (Gas)	CC114704
Flashback Arrestors-for hose Ø6-8mm (Oxygen)	CC114705
Flashback Arrestors-for hose Ø6-8mm (Gas)	CC114706
Male quick connector Argon/Co2 Ø6-8mm	CC114707
Female quick connector Argon/Co2 Ø6-8mm	CC114708
Female quick connector Oxygen Ø6-8mm (without flashback)	CC114709
Female quick connector Gas Ø6-8mm (without flashback)	CC114710
Oxygen hose 6,3 x 12,3mm (20m)	CC114904
Oxygen hose 8,0 x 15,0mm (50m)	CC114895
Oxygen hose 10,0 x 17,0mm (20m)	CC114896
Acetylene hose 6,3 x 12,3mm (20m)	CC114897
Acetylene hose 8,0 x 15,0mm (50m)	CC114898
Acetylene hose 10,0 x 17,0mm (20m)	CC114899
Propane hose 8,0 x 15,0mm (20m)	CC114900
Oxygen / Acetylene hose 6,3mm (25m)	CC114901
Oxygen / Acetylene hose 8,0mm (25m)	CC114902
Oxygen / Acetylene hose 10,0mm (25m)	CC114903



CI Cutting torch

Ref.



Cutting Torches-450mm - 90° head	CC114711
Cutting Torches-750mm - 90° head	CC114712
Cutting Torches-1000mm - 75° head	CC114713
Cutting Torches-1500mm - 75° head	CC114714
Cutting Guide 80-800mm	CC114715
Acetylene cutting nozzle 3-6mm	CC114716
Acetylene cutting nozzle 5-12mm	CC114717
Acetylene cutting nozzle 10-75mm	CC114718
Acetylene cutting nozzle 70-100mm	CC114719
Acetylene cutting nozzle 90-150mm	CC114720
Acetylene cutting nozzle 140-200mm	CC114721
Acetylene cutting nozzle 190-300mm	CC114722
Acetylene cutting nozzle 300-500mm	CC114723
Propane cutting nozzle 3-6mm	CC114724
Propane cutting nozzle 5-12mm	CC114725
Propane cutting nozzle 10-75mm	CC114726
Propane cutting nozzle 70-100mm	CC114727
Propane cutting nozzle 90-150mm	CC114728
Propane cutting nozzle 140-200mm	CC114729
Propane cutting nozzle 190-300mm	CC114730
Propane cutting nozzle 300-500mm	CC114731

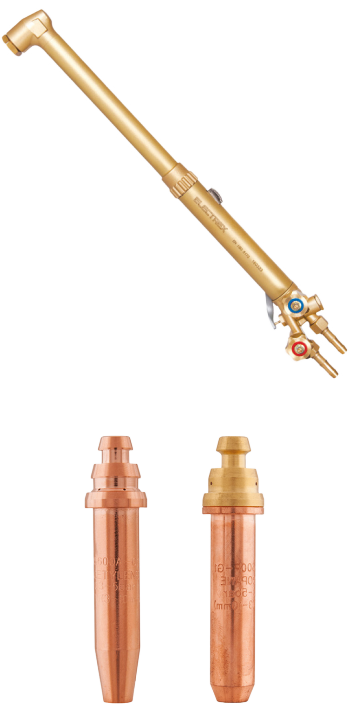

CUTTING TORCHES

G1 Cutting torch	Ref.	
	Cutting Torches-G1 - 90° head	CC114732
	Acetylene cutting nozzle G1 3-10mm 7/10	CC114733
	Acetylene cutting nozzle G1 10-25mm 10/10	CC114734
	Acetylene cutting nozzle G1 25-50mm 12/10	CC114735
	Acetylene cutting nozzle G1 50-80mm 16/10	CC114736
	Acetylene cutting nozzle G1 80-120mm 20/10	CC114737
	Acetylene cutting nozzle G1 120-200mm 25/10	CC114738
	Acetylene cutting nozzle G1 200-300mm 30/10	CC114739
	Propane cutting nozzle G1 3-10mm 7/10	CC114740
	Propane cutting nozzle G1 10-25mm 10/10	CC114741
	Propane cutting nozzle G1 25-50mm 12/10	CC114742
	Propane cutting nozzle G1 50-80mm 16/10	CC114743
	Propane cutting nozzle G1 80-120mm 20/10	CC114744
	Propane cutting nozzle G1 120-200mm 25/10	CC114745
	Propane cutting nozzle G1 200-300mm 30/10	CC114746

H Cutting torch	Ref.	
	Acetylene Cutting Torches-450mm - 90° head	CC114747
	Propane Cutting Torches-450mm - 90° head	CC114748
	Cutting Guide H 80-800mm	CC114749
	Cutting nozzle H 000 A 0-5mm	CC114750
	Cutting nozzle H 00 A 5-10mm	CC114751
	Cutting nozzle H 0 A 10-15mm	CC114752
	Cutting nozzle H 1 A 15-25mm	CC114753
	Cutting nozzle H 2 A 25-50mm	CC114754
	Cutting nozzle H 3 A 50-100mm	CC114755
	Cutting nozzle H 4 A 100-175mm	CC114756
	Cutting nozzle H 5 A 175-250mm	CC114757
	Cutting nozzle H 6 A 250-300mm	CC114758
	Cutting nozzle H 000 AC 1-5mm	CC114759
	Cutting nozzle H 00 AC 5-10mm	CC114760
	Cutting nozzle H 0 AC 10-15mm	CC114761

CUTTING TORCHES



Cutting nozzle H 1 AC 15-25mm	CC114762
Cutting nozzle H 2 AC 25-50mm	CC114763
Cutting nozzle H 3 AC 50-75mm	CC114764
Cutting nozzle H 4 AC 75-150mm	CC114765
Cutting nozzle H 5 AC 150-200mm	CC114766
Cutting nozzle H 6 AC 200-300mm	CC114767
Cutting nozzle H 000 P 1-5mm	CC114768
Cutting nozzle H 00 P 5-10mm	CC114769
Cutting nozzle H 0 P 10-15mm	CC114770
Cutting nozzle H 1 P 15-25mm	CC114771
Cutting nozzle H 2 P 25-50mm	CC114772
Cutting nozzle H 3 P 50-75mm	CC114773
Cutting nozzle H 4 P 75-150mm	CC114774
Cutting nozzle H 5 P 150-200mm	CC114775
Cutting nozzle H 6 P 200-300mm	CC114776

Cutting / Welding / Heating Kit

Ref.

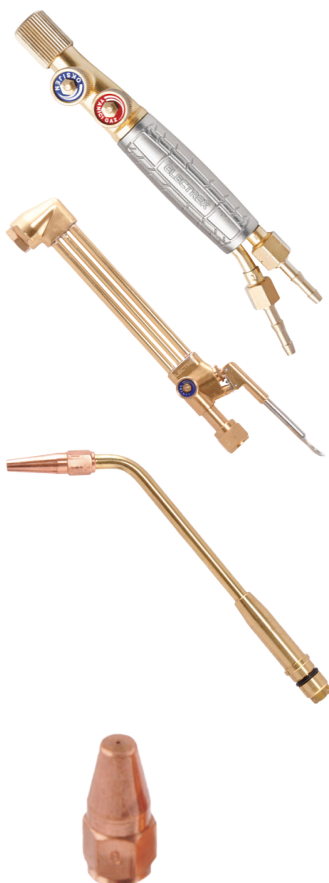

Shank 16mm - G1/4 - G3/8L	CC114777
Cutting Torch (0-300mm)	CC114778
Welding Neck + Nozzle No:0 0,2-0,5 MM	CC114779
Welding Neck + Nozzle No:1 0,5-1 MM	CC114780
Welding Neck + Nozzle No:2 1-2 MM	CC114781
Welding Neck + Nozzle No:3 2-4 MM	CC114782
Welding Neck + Nozzle No:4 4-6 MM	CC114783
Welding Neck + Nozzle No:5 6-9 MM	CC114784
Welding Neck + Nozzle No:6 9-14 MM	CC114785
Welding Neck + Nozzle No:7 14-20 MM	CC114786
Welding Neck + Nozzle No:8 20-30 MM	CC114787
Welding Nozzle No:0 0,2-0,5 MM	CC114788
Welding Nozzle No:1 0,5-1 MM	CC114789
Welding Nozzle No:2 1-2 MM	CC114790
Welding Nozzle No:3 2-4 MM	CC114791
Welding Nozzle No:4 4-6 MM	CC114792
Welding Nozzle No:5 6-9 MM	CC114793



CUTTING TORCHES

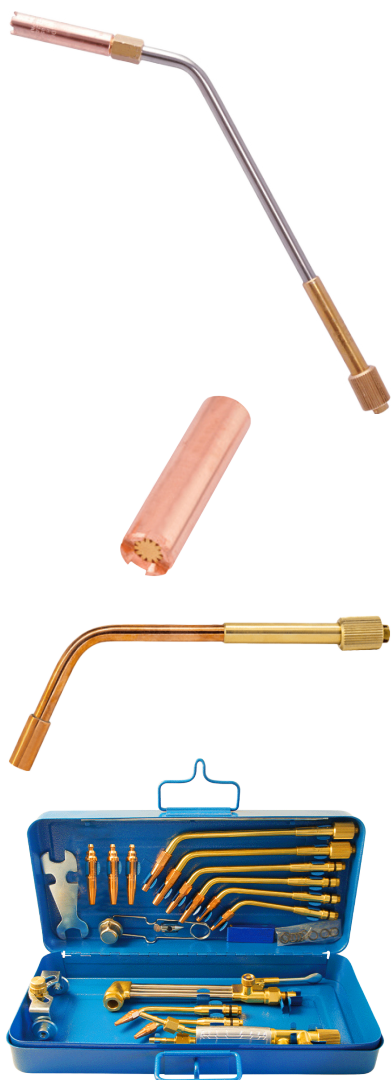

Welding Nozzle No:6 9-14 MM	CC114794
Welding Nozzle No:7 14-20 MM	CC114795
Welding Nozzle No:8 20-30 MM	CC114796
Heating Neck + Propane Nozzle No:1	CC114797
Heating Neck + Propane Nozzle No:2	CC114798
Heating Neck + Propane Nozzle No:3	CC114799
Heating Neck + Propane Nozzle No:4	CC114800
Heating Neck + Propane Nozzle No:5	CC114801
Propane heating Nozzle No:1	CC114802
Propane heating Nozzle No:2	CC114803
Propane heating Nozzle No:3	CC114804
Propane heating Nozzle No:4	CC114805
Propane heating Nozzle No:5	CC114806
Heating Neck + Acetylene Nozzle No:4 MFA	CC114807
Heating Neck + Acetylene Nozzle No:6 MFA	CC114808
Heating Neck + Acetylene Nozzle No:8 MFA	CC114809
Heating Neck + Acetylene Nozzle No:10 MFA	CC114810
Welding (0,5-30mm) e cutting (0-300mm) case	CC114811
Set Shank + Cutting torch 4429 Acetylene (0-100mm)	CC114812
Set Shank + Cutting torch 4429 Propane (0-100mm)	CC114813
Injector Type Cutting attachment Acetylene (0-100mm)	CC114814
Injector Type Cutting attachment Propane (0-100mm)	CC114815
Shank	CC114816

Welding torch

Ref.



Welding Torch + 7 nozzles Acetylene	CC114817
Welding Nozzles 7 - Acetylene	CC114818
Welding Nozzles 7 - Propane	CC114819

Propane heating and welding torch

Ref.



Propane shank with trigger G3/8L - Ø6-8mm	CC114821
Neck with pipe heating nozzle Ø22mm	CC114822
Pipe heating nozzle Ø22mm	CC114823
Connection Neck 60 mm	CC114824

CUTTING TORCHES

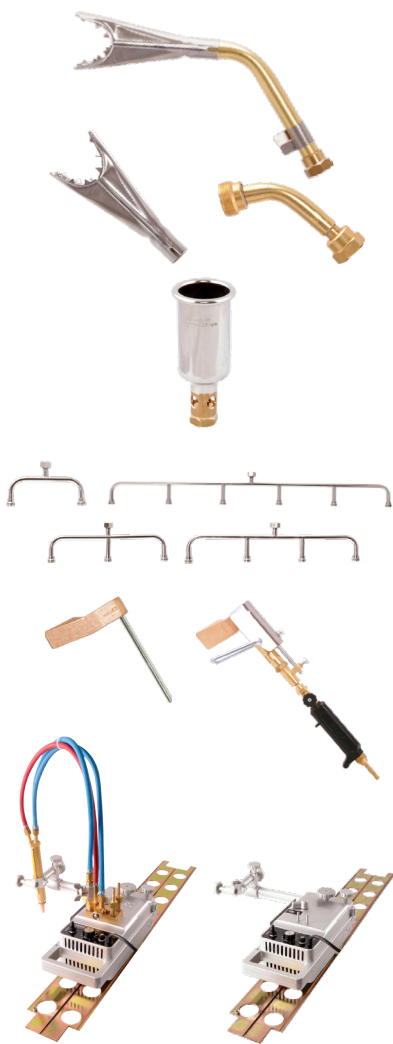

Connection Neck 100 mm	CC114825
Connection Neck 200 mm	CC114826
Connection Neck 400 mm	CC114827
Connection Neck 600 mm	CC114828
Connection Neck 750 mm	CC114829
Connection Neck 1000 mm	CC114830
Propane heating nozzle Ø45	CC114831
Propane heating nozzle Ø51	CC114832
Propane heating nozzle Ø57	CC114833
Propane heating nozzle Ø63	CC114834
Connection Neck 2 nozzles	CC114835
Connection Neck 3 nozzles	CC114836
Connection Neck 4 nozzles	CC114837
Connection Neck 6 nozzles	CC114838
Propane Soldering Set 500 gr G3/8L - Ø6-8mm	CC114839
Copper Bit 350 gr	CC114840
Copper Bit 500 gr	CC114841
Sharp Copper Bit 250gr	CC114842
Sharp Copper Bit 350gr	CC114843
Automatic oxy-gas cutting machine with single cutting torch + 2m rail	CC114844
Automatic plasma cutting machine with single plasma torch + 2m rail	CC114845

Other accessories

Ref.



Propane cylinder trolley standard	CC114894
Oxygen-acetylene cylinder trolley standard (2 bottles)	CC114890
Oxygen-propane cylinder trolley standard (2 bottles)	CC114891
Oxygen cylinder trolley reinforced	CC114892
Oxygen cylinder trolley standard	CC114893
Spark lighter with torch flint	CC114289
Torch lighter flint (5 pcs)	CC114859
Welding tip cleaner	CC114290
Safety glasses ø50mm	CC114291



PLASMA ACCESSORIES

Plasma torch Tecmo

Plasma torch PT60



CC105807

Plasma torch PT100



CC105773

Plasma torch PTM100



CC111993

TECMO torches

Ref.

PT 60

Cutting tip 0,65mm PT60 (1)	CC105816
Cutting tip 0,80mm PT60 (1)	CC105815
Cutting tip 0,90mm PT60 (1)	CC105103
Cutting tip 1.10 mm 50-60A PT60 (1)	CC111728
Contact cutting tip 1,00mm PT60 (1)	CC106882
Contact cutting tip 1,10mm PT60 (1)	CC111548
Air diffuser PT60 (2)	CC105104
Electrode plasma PT60 (3)	CC105105
Nozzle PT60 (4)	CC105101
Threaded nozzle PT60 (14)	CC111559
Contact Cutting nozzle threaded PT60 (13)	CC111560
2 pin spacer PT60 (5)	CC105102
Circular cutting compass PT60 (6)	CC112207
Plasma cutting torch body PT60 (7)	CC105808
Handle PT60 (8)	CC105811

PT 100

Cutting tip 1,40mm PT100 (1)	CC105108
Cutting tip 1,50mm PT100 (1)	CC105109
Contact cutting tip 1,50mm PT100 (1)	CC112177
Nozzle gouging PT100 (1)	CC111309



Air diffuser PT100 (2)	CC105110
Air flow regulator PT100 (9)	CC105112
Plasma Electrode PT100 (3)	CC105111
Nozzle PT100 (4)	CC105106
Threaded nozzle PT100	CC111310
Contact cutting tip PT100	CC112178
Nozzle gouging PT100	CC111311
2 pins spacer PT100	CC105107
Circular cutting compass PT100	CC112208
Plasma cutting torch body PT100	CC105810
Plasma cutting torch body PTM100	CC111994
Handle PT100 cpl	CC105813
O'ring PTM100	CC111995
Fiberglass positioning tube PTM100	CC111996
Torch switch PT60/100	CC105814

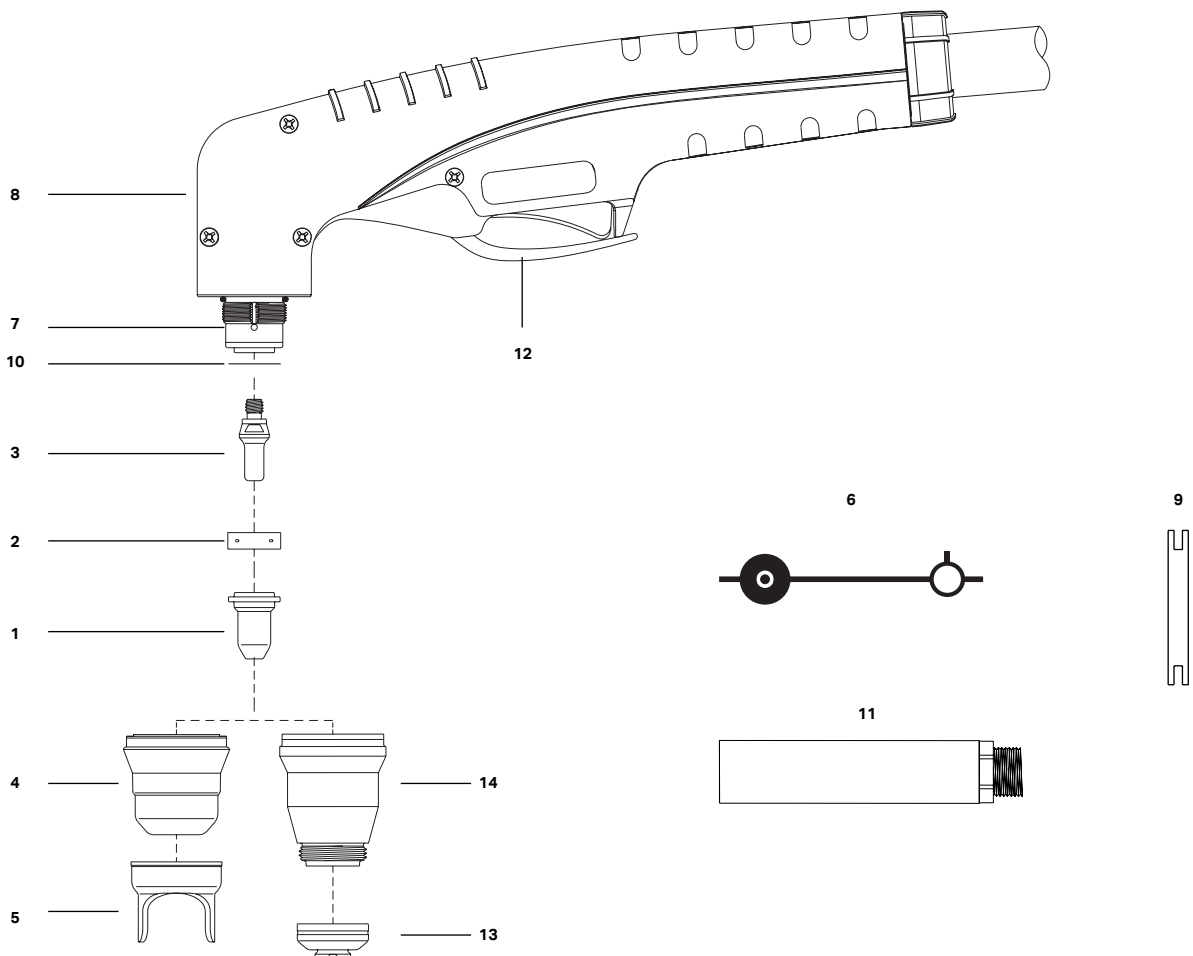



PLASMA ACCESSORIES

Plasma torches Trafimet

Plasma torch A101



Manual	CC3101C131061
Auto	CC107916

Plasma torch A151



Manual	CC3151C131061
Auto	CC3150C132062

Trafimet torches

Ref.



Air flow regulator FH562 A101 (1)

CC3100C120000



Air flow regulator FH563 A151 (1)

CC3150C120000

Air diffuser PE101 A101 (2)

CC3000C040003

Air diffuser PE103 A151 (2)

CC3000C040004



Standard electrode PR101 A101 (3)

CC3000C060000

Standard electrode PR111 A151 (3)

CC3145C060000



Long electrode PR116 A101/151 (4)

CC3000C060001



Cutting tip PD101 1,10mm A101 (4)

CC3000C010111

Cutting tip PD101 1,40mm A101 (4)

CC3000C010141

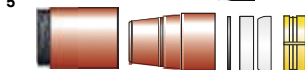

Cutting tip PD109 1,40mm A151 (4)

CC3145C010141

Cutting tip PD109 1,60mm A151 (4)

CC3145C010161

Cutting tip PD101 1,70mm A101 (4)

CC3000C010171

Cutting tip PD109 1,80mm A151 (4)

CC3145C010181

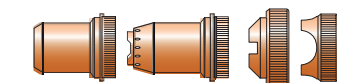

Cutting tip PD101 1,90mm A101 (4)

CC3000C010191



Long cutting tip PD117 1,40mm A101/151 (4)

CC3000C010143

Long cutting tip PD117 1,70mm A101/151 (4)

CC3000C010173

Long cutting tip PD117 1,90mm A101/151 (4)

CC3000C010193



Standard nozzle PC109 A101 (5)

CC3090C020003

Standard nozzle PC120 A151 (5)

CC104561

Standard nozzle PC101 A151(5)

CC3140C020003

Contact cutting nozzle PC130 A101(5)

CC3100C020004



Trafimet torches		Ref.
7	Contact cutting nozzle PC103 A151 (5)	CC3140C020004
	8	Spacer ring CV11 A101/151
9	Long contact spacer CV09 A101/151 (6)	CC3000C050005
	Long contact spacer CV1105 A101/151 (6)	CC104560
10	Spacer CV0014 A101/151(6)	CC102556
	Spacer CV0039 A101/151(6)	CC102555
	Rotating spacer CV21 A101/151(6)	CC3000C050004
	Cutting guide 500mm for circle cutting	PF100793
	Cutting guide center pin for circle cutting	PF100794
	Plasma cutting torch body A101 (7)	CC3100C030001
Plasma cutting torch body A151 (7)	CC3150C030001	
Plasma cutting torch body A151 automatic (7)	CC100483	
Plasma cutting torch body A101 automatic (7)	CC3100H030002	
O'ring Plasma cutting torch body A101/151 (8)	CC104559	
Handle A101/151 (9)	CC100437	
Torch switch A101/151 (10)	CC1000C120002	

ELECTREX SERVICE

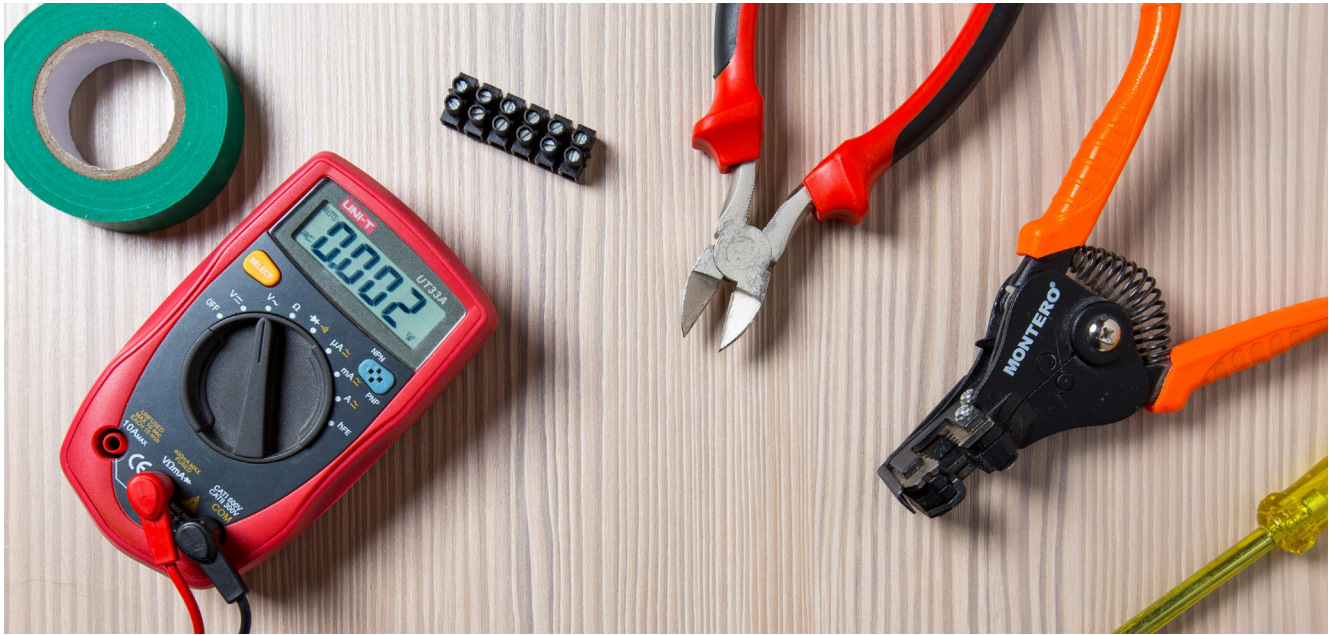

TECHNICAL ASSISTANCE

We have a specialized technical team at your disposal, with approved repair procedures and with original Electrex spare parts.



WARRANTY

Our equipment is manufactured with rigorous production processes and tested to operate under the most demanding conditions, guaranteeing its reliability and durability.



DO YOU HAVE TECHNICAL QUESTIONS?

At Electrex we are always available to listen and answer the needs of our customers as soon as possible. Use our fast **WhatsApp** communication channel to solve your questions or technical difficulties.

Luciano Santos:

 (+351) 961 939 968



● Distribution points

📍 Electrex Portugal

ELECTREX - João R. Matos S.A.
Rua do Viso - Santa Joana
3810-375 Aveiro | PORTUGAL

Tel.: (+351) 234 313 433
Fax: (+351) 234 313 024

info@electrexwelding.com
www.electrexwelding.com



WELDING SINCE 1946

ELECTREX - João R. Matos S.A.
Rua do Viso - Santa Joana
3810-375 Aveiro | PORTUGAL

Telf: (+351) 234 313 433
Fax: (+351) 234 313 024



info@electrexwelding.com
www.electrexwelding.com

